

# LASER LEVEL KIT

Model #9100/40-0909

## ASSEMBLY & OPERATING MANUAL



 **JOHNSON**<sup>®</sup>  
LEVEL & TOOL

## ABOUT THIS PRODUCT

This leveling instrument uses a laser beam to plot distant points or lines. The sleeve, or main body, of this spirit level is made of heavy-duty aluminum and contains two level vials (horizontal and adjustable) as well as a semi-conductor laser.

When installed on the leveling base and rotated 360-degrees, the laser point (beam) of this level will always project at a constant horizontal. The lightweight, yet sturdy, tripod quickly sets the laser point at the required height. The laser point attachments included in the kit help find level and plumb points easily. These attachments can be adjusted to any angle.

This level may be used both indoors and out. It is suitable for contractors and DIY'ers alike.

## ACCESSORIES INCLUDED

- 360-degree rotating leveling base
- Telescoping tripod
- 90-degree angle deviator (splitter) lens
- Line projection (spreader) lens
- Tinted goggles
- 2 AAA (1.5V) batteries

### ATTENTION!



### ATTENTION!

- Never look into the laser beam without certified eye protection. Improper use of this laser level may cause injury to the eyes.
- Do not direct laser beam at another person or reflective surfaces. Even a lower capacity laser beam may cause injury to the eyes.
- Store laser level out of children's reach. It is not a toy.
- Any change to the laser level resulting in increased performance is strictly prohibited. Any claim for damages due to injuries resulting from the non-compliance of these safety instructions will be refused.
- When storing laser level for time periods over 3 months, remove the batteries from the unit in order to avoid damage due to battery leaks.
- This laser level does not contain any serviceable parts. Never open the housing, as this will void the warranty.

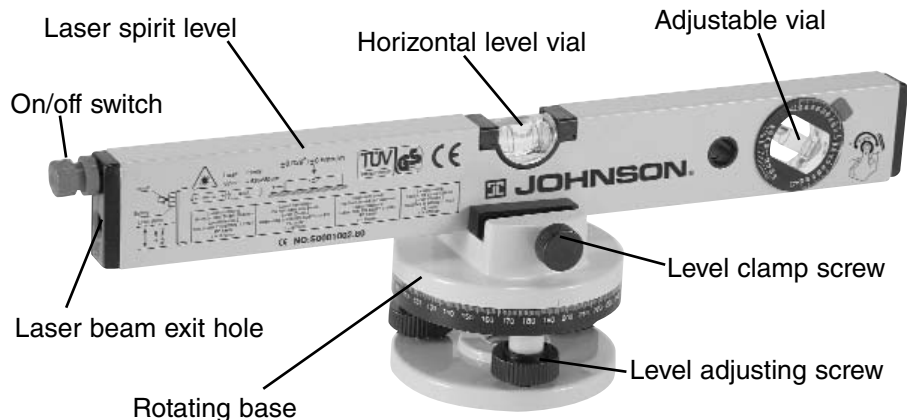

## INSERTING/CHANGING BATTERIES & ACTIVATING THE LASER BEAM

Open the red, threaded connector and insert the two AAA (1.5V) batteries as shown on the diagram printed on the level sleeve.

To turn the laser level “on,” rotate the knob located above the laser beam exit hole in a clockwise direction. To turn the beam “off,” rotate the knob counter-clockwise.

Note: Used (discharged) batteries are hazardous waste and must be disposed of properly.

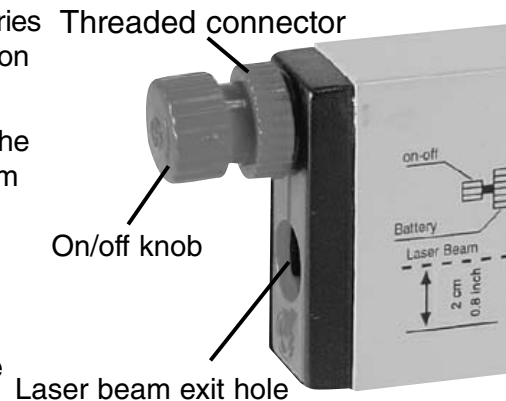

TECHNICAL INFORMATION	
Class 2 Laser; Class 3 Protection	
Length of Level:	15-3/4" (40cm)
Measuring Range:	40-45m
Measuring Accuracy:	+/- 1/4" at 40 ft. (+/- 0.5mm/m)
Maximum Yield:	<1mW
Wavelength:	630-680nm
Power Supply:	2 AAA (1.5V) batteries

## ASSEMBLY & ADJUSTMENT

Expand the legs of the tripod and position it firmly on an even, near-level surface. On uneven surfaces and inclines, compensate by adjusting the telescoping legs of the tripod and find level with the aid of the built-in Bull’s Eye™ centering vial (found at the top of the tripod’s base).

Tightly screw the rotating leveling base and tripod together.

Bring the leveling plate of the base into a level position by means of the three adjusting screws and the built-in Bull’s Eye™ centering vial.

Place the spirit level on the leveling plate and tighten it with the locking clamp. Check to ensure the vial registers level. Use the regulating screws to adjust. (Center the bubble exactly between the markings on the vial).

Loosen the “stop” screw, rotate the level 90 degrees and check for level again using one of the other adjusting screw(s)--if necessary. Return to original position and re-check, re-adjusting if required.

The elevation of the laser point can be fixed to the desired position using the tripod’s handle crank. Use the degree scale on the leveling base to set the level at the required angle.

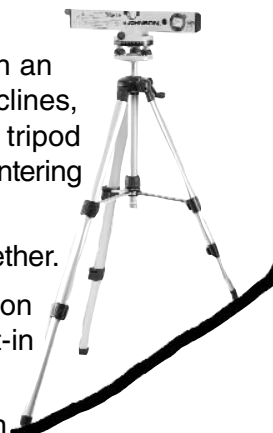

### WARNING!

**DO NOT LOOK DIRECTLY INTO THE LIGHT BEAM.  
DO NOT AIM LIGHT BEAM DIRECTLY INTO EYES.  
THIS WILL DAMAGE THE EYES.**



## 90° ANGLE/ BEAM SPLITTING OPTION

By inserting the splitter lens into the laser beam exit hole, the emerging laser beam is split by 90 degrees. This generates a vertical (perpendicular) reference line to the standard, horizontal laser beam.

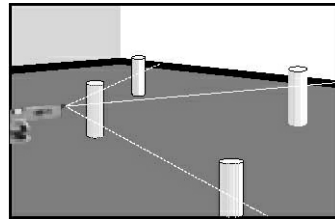
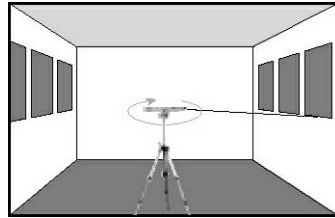
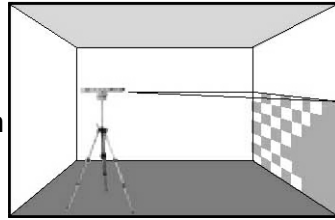

## LINE PROJECTION

By mounting the line projector attachment, a line will be projected onto the wall (instead of a point). In order to achieve the most accurate line, mark two points with the help of the point beam. Mount the line projector attachment and connect these points with the projected line. Please note: Use of the line projection lens results in a loss of brightness.

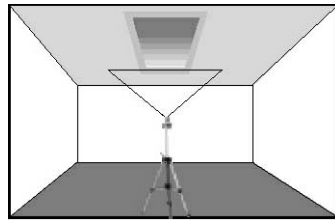
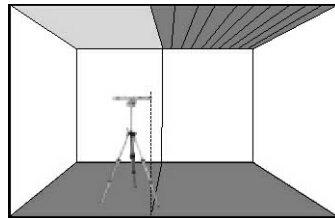

### WARNING!

**DO NOT LOOK DIRECTLY INTO THE LIGHT BEAM.  
DO NOT AIM LIGHT BEAM DIRECTLY INTO EYES.  
THIS WILL DAMAGE THE EYES.**



## GUARANTEE STATEMENT

This Laser Level Kit is guaranteed against all defects in construction and material. This guarantee is limited to the replacement of defective parts upon presentation of the original sales receipt. This guarantee is not applicable in the event of, but not limited to, damage due to misuse by failing to heed the instructions presented herein, of unauthorized manipulation of the level and its attachments, or upon negligence of the purchaser/user.

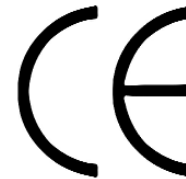

NF EN 60825-1 1997  
NF EN 60825-1/A1 2000



CLASS 2 LASER